



**STEERING BRAKE KIT
FOR
PROFESSIONAL 2-WHEEL TRACTOR**

NOTE

Read this manual carefully and learn to operate and service your steering brake before using it.

To keep the warranty, the steering brake must be maintained and operated as directed in this manual.

All references to "left-side", "right-side", "front", and "back" are given from the operator's position.

Use the serial numbers to ensure prompt and correct service when ordering parts, requesting service, or making inquiries.

STEERING BRAKE SERIAL NUMBER _____

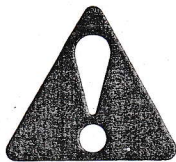

Look for this symbol to point out important safety precautions. It means -- ATTENTION! BECOME ALERT! YOUR SAFETY IS INVOLVED.

CONTENTS

1. INSTRUCTIONS FOR SAFE OPERATION
2. OPERATING INSTRUCTIONS
3. SERVICE INSTRUCTIONS
4. ILLUSTRATED PARTS AND PARTS LIST
5. INSTALLATION INSTRUCTIONS
6. WARRANTY

SECTION 1

Instructions for Safe Operation

Improper use of this equipment can injure people and damage the equipment. People using or servicing this equipment must read and follow the instructions in this manual.

It is important to understand that this manual and any other Gravely instruction manuals do not cover every possible danger. It is impossible for Gravely to know all possible dangers in operating and servicing the equipment.

The purchaser must give these instructions to the people operating and maintaining this equipment. These people must use eye and foot protection.

1.1 Preparation:

1. Read this manual carefully.
2. Learn the location and function of all controls.
3. Learn how to use the controls to stop the wheels and mower quickly.
4. Use caution with gasoline. Gasoline is very flammable. Keep it in a clean and tight container away from flames or hot items. Never put gasoline in the fuel tank while the engine is running or hot. Clean up spilled gasoline before starting engine.
5. Be certain that all shields, guards, and interlock switches are in the correct position.
6. Never permit children to operate the equipment.
7. Inspect area to be mowed and remove all material which could be thrown by the mower.
8. Before starting the engine, put the PTO control lever in the "OFF" position and the gear shift lever in the neutral "N" position.
9. When hauling the equipment, connect the chassis to the transporting vehicle. Never connect from control levers, rods, or like items that could be damaged.
10. Replace all parts that become damaged or lost.
11. Check the operation of the operator presence controls before operating the mower.

1.2 Operation

1. Wear foot and eye protection. Do not wear loose clothing.
2. Do not use the equipment in the dark without adequate lighting.
3. Keep the equipment in good condition. Maintain it as directed in this manual.
4. USE ONLY GRAVELY ACCESSORIES AND ATTACHMENTS.
5. Do not overspeed the engine. Do not override the governor.
6. Keep away from moving parts.
7. Keep people and animals away from the operating area.
8. Do not let people other than the operator near the operating equipment.
9. Use a slow speed and engage the shift lever slowly when operating on slopes.
10. Look for and keep away from hazards.
11. After hitting an object, stop the equipment and engine. Check for damage. Repair any damage before continuing operation.
12. Look behind when operating in reverse. Look for people and hazards.
13. Operate only from the operator's position, just behind the handlebars.
14. Travel across slopes only when using a sulky.
15. If there is a sudden change in the sound or vibration of the equipment, stop the engine and check for damage. Repair any damage or failure before continuing operation.
16. Never run the engine indoors except to move it outside. Exhaust fumes are dangerous.
17. Go slowly on slick surfaces.
18. Follow traffic laws when operating on or near a road.
19. Before making adjustments or servicing, move the PTO to "OFF", turn the ignition switch to "OFF", and wait until all moving parts completely stop.
20. Before leaving the operator's position, put the PTO lever in the "OFF" position, turn the ignition key to the "OFF" position. Lock the brake lock. Wait until all moving parts have stopped.

SECTION 2

Operating Instructions

2.1 Steering Brake Operation:

When the tractor is going forward, swing the brake handle bar clockwise for a right turn or counterclockwise for a left turn.

 **CAUTION:** Use only the tractor handle bars to steer when going in reverse.

2.2 Parking Brake Operation:

Pull the parking brake handle all the way up and release. To disengage, push the brake handle down.

2.3 Operator Presence Control:

One of the operator presence control levers must be depressed so the power take off (PTO) or Fwd-Rev lever can be operated.

 **CAUTION:** The operator presence control is to protect the operator from the moving parts of the attachment and the powered moving of the equipment. Operate the equipment only when the operator presence control is in working condition.

SECTION 3

Service Instructions.

3.1 Steering Brake Adjustment:

1. Park the tractor in a level area.
2. Put the parking brake handle in the "OFF" (down) position.
3. Loosen the jam nuts on the right and left brake rod assemblies. See Figures 1 and 2.
4. Loosen the jam nuts below the compression spring on the right side of the tractor and adjust until one has the desired tension for the right brake. When correctly adjusted the nut should be .50 to .75 inches from the end of the rod as shown in Figure 1.
5. Tighten the jam nuts.
6. Turn the adjusting nuts until the brake handle cross bar is parallel with the instrument panel.
7. Move the brake handle all the way to the right and measure the distance from the right end edge of the brake handle cross bar to the right side of the instrument panel. Move the brake handle bar all the way to the left and make the same measurement on the right. Adjust the nuts until the difference between the two measurements is 1/2" to 3/4" (13 to 19 mm). Turn both adjusting nuts the same amount, clockwise to increase the measurement difference or counterclockwise to decrease the measurement difference.
8. Tighten the jam nuts.

3.2 Adjusting the Operator Presence Control Levers:

Move the lock nut until the lever weldment just clears the body of the interlock switch.

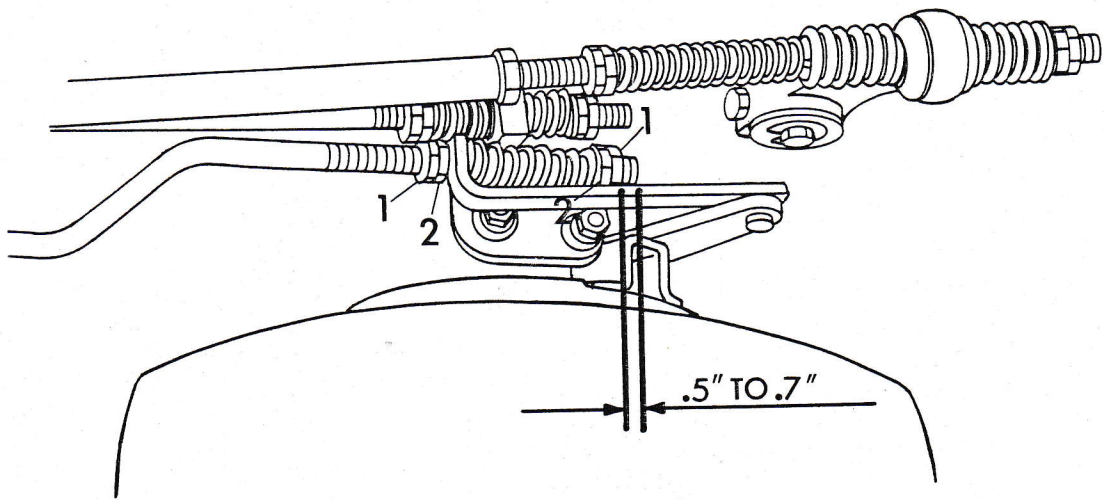

- 1 - Jam Nuts
 - 2 - Adjusting Nuts
- FIGURE 1

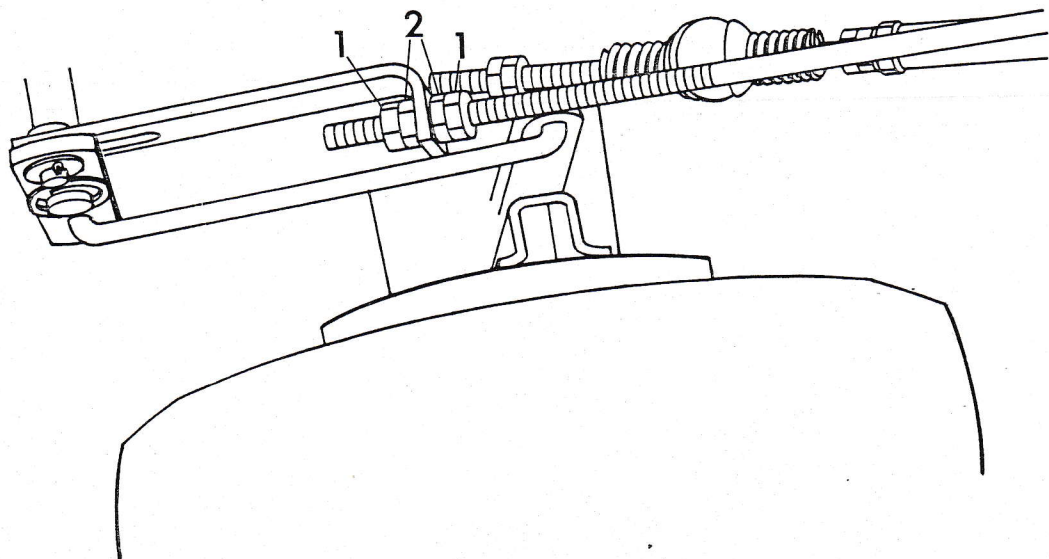

- 1 - Jam Nuts
 - 2 - Adjusting Nuts
- FIGURE 2

SECTION 4

Illustrated Parts and Parts List

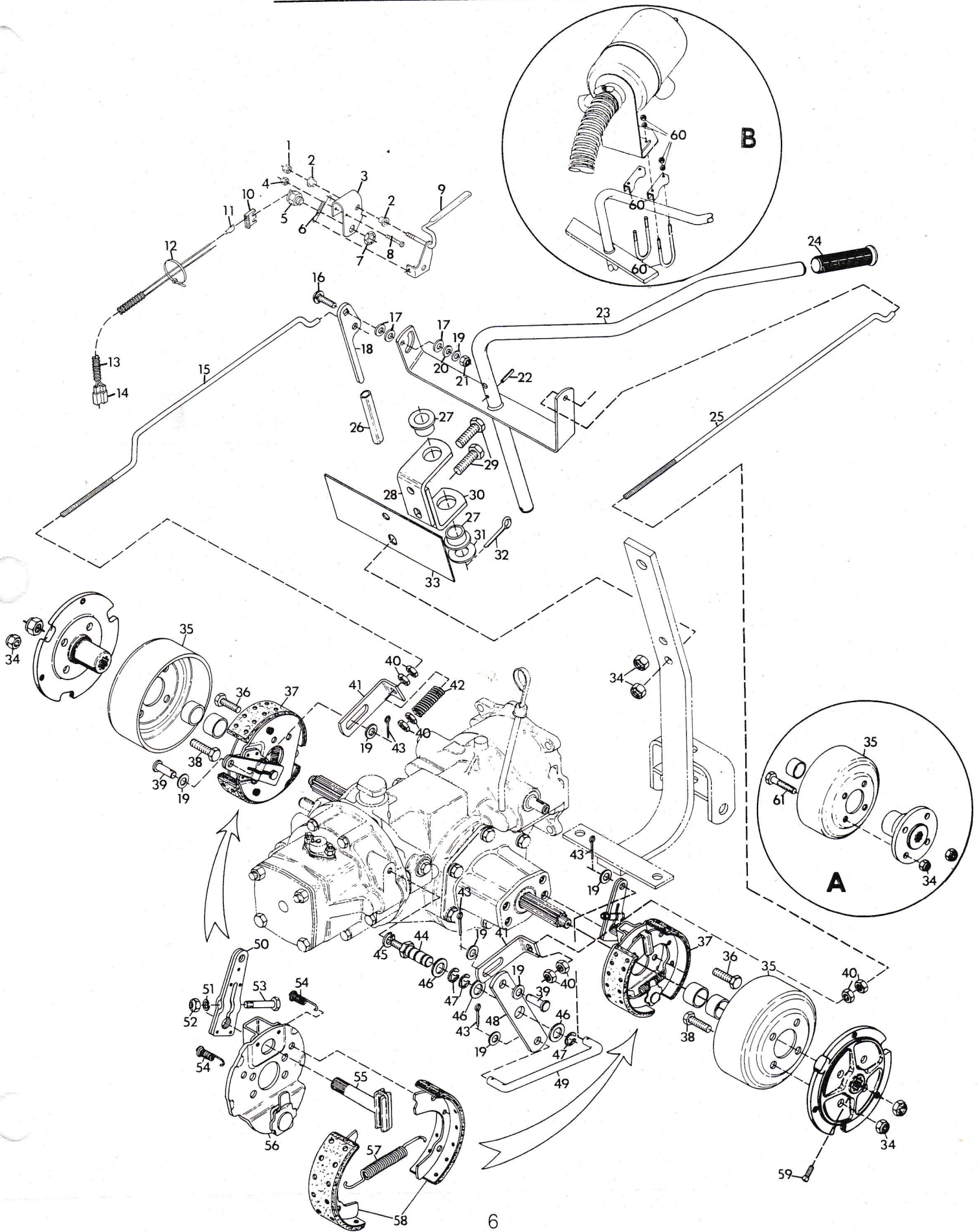

ITEM NO.	PART NO.	QTY.	DESCRIPTION
1	419455	1	Nut, Lock 5/16-18
2	41988	2	Bushing, Interlock Lever
3	44099	1	Bracket, Interlock Mounting
4	190254	1	Nut, Lock 10-24
5	20916	1	Switch, Interlock
6	41551	1	Spring, Interlock
7	107354	1	Nut, Stamped 9/16-18
8	436738	1	Screw, Mach. 10-24x1.50 PHD
9	42133	1	Weldment, Handle
10	42176	1	Connector, 2-Wire Switch
11	38059	2	Terminal
12	41634	2	Tie Wrap, Black
13	42198	1	Harness, Steering Brake
14	38057	1	Connector
15	42000	1	Rod, Brake
16	126411	1	Bolt, 3/8-16x1.50 Rd Hd Sq Nk
17	20775	3	Washer, Nylon .375x.75x.060
18	23391	1	Handle, Parking Brake
19	120394	8	Washer, Flat .406x.812x.065
20	23394	1	Washer, Rubber .375x.75x.125
21	456004	1	Nut, Lock 3/8-16
22	273921	1	Pin, Spring .31x2.00
23	41845	1	Weldment, Brake Handlebar
24	41563	1	Grip, Handlebar
25	42020	1	Rod, Brake L.H.
26	44347	1	Grip, Brake Handle
27	18355	2	Bushing, Pivot
28	41851	1	Bracket, Brake Handle
29	180181	2	Bolt, Hex 1/2-13x2.00
30	41850	1	Bracket, Brake Handle
31	103348	1	Washer, Flat 1.063x2.000x.134
32	103409	1	Pin, Cotter .188x1.500
33	43395	1	Plate, Instruction
34	435507	10	Nut, Lock 1/2-13
35	23385	2	Drum, 7x1.75
36	180121	8	Bolt, Hex 3/8-16x.875
37	23384	2	Brake, 7x1.75 Mechanical
38	180176	8	Bolt, Hex 1/2-13x1.375
39	431780	2	Pin, Clevis .375x.750
40	124829	8	Nut, Jam 3/8-16
41	23389	2	Bracket, Adjustment
42	23392	1	Spring, Compression
43	121222	4	Pin, Cotter .09x.75
44	41847	1	Stud, Pivot
45	120384	1	Washer, Lock 1/2 Reg.

ITEM NO.	PART NO.	QTY.	DESCRIPTION
46	131016	5	Washer, Flat .656x1.312x.095
47	18053	3	E-Ring, .625 Shaft
48	23387	1	Plate, Pivot
49	23388	1	Rod, Brake Link
50	23505	2	Arm, Cam Lever
51	120214	2	Washer, Lock 5/16 Reg.
52	120368	2	Nut, Hex 5/16-24
53	181618	2	Bolt, Hex 5/16-24x1.75
54	23509	4	Spring, Shoe Retaining
55	23506	2	Cam, Brake
56	23507	2	Plate, Back
57	23508	2	Spring, Shoe Return
58	23539	2	Kit, Brake Shoe
59	102905	2	Screw, Set 7/16-14x.75 CPSH
60	14728	2	Clamp, Muffler
61	180178	8	Bolt, Hex 1/2-13x1.625

NOTE: Circle "A" pertains to wheel and hub assembly - 18x8.50-8.
Circle "B" pertains to wheel brake and remote air cleaner combination.

SECTION 5

Installation Instructions

- 5.1 Remove the kit from the shipping container.
- 5.2 Fasten the instruction plate and the brake handle brackets to the rear hitch with the 1/2-13x2.00 bolts and 1/2" lock nuts.
- 5.3 Right Side Installation:
 1. Raise and block the right side of the tractor.
 2. Unbolt the tire assembly from the wheel hub and remove.
 3. Remove the axle nut, flat washer and spacer. Remove the wheel hub set screw.
 4. Use a puller and remove the wheel hub.
 5. Remove the four bolts that retain the end plate to the axle housing. NOTE: Do not remove the end plate.
 6. Slide the brake assembly over the axle. Rotate until the holes in the back plate align with the holes in the end plate and axle housing (cam lever arm at 2 o'clock position). Retain with four 3/8-16x7/8" bolts. If necessary, turn the bolt in the cam lever arm to where the lock washer and nut face away from the axle housing.
 7. Slide the brake handle onto the rear of the right hand brake rod assembly and insert the rod into the slot of the brake handlebar weldment. Place the carriage bolt through the brake handle, and put two nylon washers on the bolt between the handle and the handlebar weldment. Push the bolt through the handle bar weldment and retain with another nylon washer, rubber washer, steel washer, and lock nut. Connect the adjustment bracket to the cam lever arm with a clevis pin, two .406x.812x.065 flat washers and a .09x.75 cotter pin. See Figure 1. See Section 3 for adjustment.
 8. Put both spacers on the axle. NOTE: The short spacer is used with the wheel hub for the 8.50x8 tire assembly.
 9. Replace the set screw in the wheel hub with a 7/16-14x3/4 set screw.
 10. Mount the brake drum to the wheel hub with four 1/2-13x1-3/8" bolts and 1/2-13 lock nuts. Four 1/2-13x1-5/8" bolts are required when the wheel hub for the 8.50x8 tire assembly is used. Note the valve stem is turned to the outside, and the 1/2-13 lock nuts should be on the outside.

11. Put a film of grease on the axle splines. Slide the wheel hub on the axle followed by a flat washer and lock nut. Tighten the nut to a torque of 80 ft.-lb. (108 Nm). Tighten the set screw.
12. Mount the tire assembly to the wheel hub.

5.4 Left Side Installation:

1. Raise and block the left side of the tractor.
2. Unbolt the tire assembly from the wheel hub and remove.
3. Remove the axle nut, flat washer and spacer. Remove the wheel hub set screw.
4. Use a puller and remove the wheel hub..
5. Remove the four bolts that retain the end plate to the axle housing. NOTE: Do not remove the end plate.
6. Slide the brake assembly over the axle. Rotate until the holes in the end plate align with the holes in the axle housing (cam lever arm at the 12 o'clock position). Retain with four 3/8-16x7/8" bolts.
7. Remove the bolt which attaches the left handlebar support to the advance casting. Install the pivot stud in the same location. See Figure 3.
8. Place the following on the pivot stud:
 - E-Ring
 - .656x1.312x.095 Flat Washer
 - Pivot Plate
 - .656x1.312x.095 Flat Washer
 - E-Ring
9. Connect the brake link rod to the pivot plate and the cam lever arm. Retain with a .406x.812x.065 flat washer and a .09x.75 cotter pin at each end.
10. Slide the rear of the left hand brake rod assembly into the left end of the handle bar weldment from the front. Connect the adjustment bracket to the pivot plate with a .375x.75 clevis pin, two .406x.812x.065 flat washers, and a .09x.75 cotter pin. See Figure 2. See Section 3 for adjustment.
11. Put both spacers on the axle. NOTE: The short spacer only is used with the wheel hub for the 8.50x8 tire assembly.
12. Replace the set screw in the wheel hub with a 7/16-14x3/4" set screw.

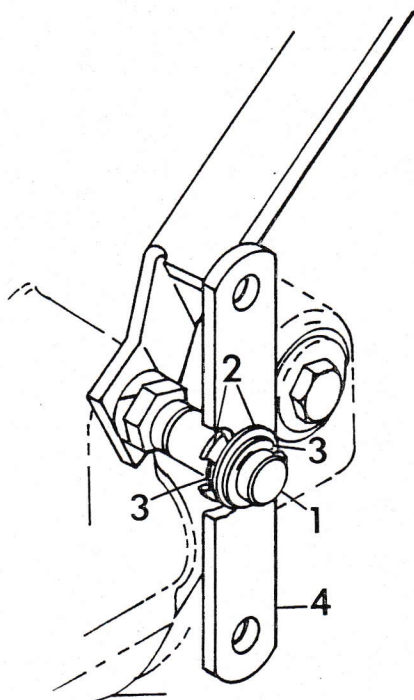

MANUAL START

1 - Pivot Stud
2 - Flat Washer

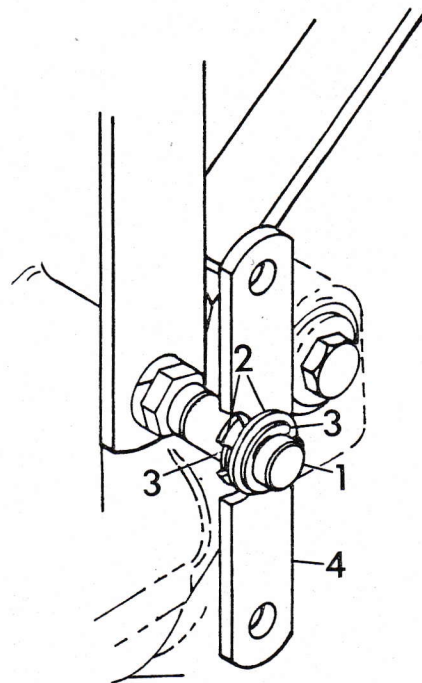

ELECTRIC START

3 - E-Ring
4 - Pivot Plate

FIGURE 3

13. Mount the brake drum to the wheel hub with four 1/2-13x 1-3/8" bolts and 1/2-13 lock nuts. Four 1/2-13x1-5/8" bolts are required when the wheel hub for the 8.50x8 tire assembly is used. Note the valve stem is turned to the outside, and the 1/2-13 lock nuts should be on the outside.
14. Put a film of grease on the axle splines. Slide the wheel hub on the axle followed by a flat washer and lock nut. Tighten the nut to a torque of 80 ft.-lb. (108 Nm). Tighten the set screw.
15. Mount the tire assembly to the wheel hub.

5.5 Adjust the brakes according to the instructions in Section 3.

5.6 Plug the steering brake wiring harness into the tractor's main wiring harness.

5.7 Check to see that interlock systems operate correctly.

SECTION 6

LIMITED FIVE-YEAR WARRANTY

1. This Limited Five-Year Warranty is issued by Gravely International, Inc., only to the original purchaser. If Gravely equipment is leased by Gravely, this Warranty shall extend also to the original lessee as if such lessee were the original purchaser.
2. Gravely warrants that all new equipment manufactured by Gravely ("Gravely Products") shall be free of defects in material and workmanship for the term described in paragraph 4, below. Except as hereinafter provided, this Warranty does not cover any engine, tires or battery forming a part of the Gravely Product. Engine and tires are covered by and subject to separate warranties of the manufacturers thereof.
3. In the event that any Gravely Product warranted hereunder shall be defective or fail to conform with this Warranty, Gravely shall, subject to the provisions hereof, pay for, or provide labor and materials for, the repair or replacement of such defective Gravely Product.
4. This Warranty is for five years (60 months) from purchase date for Gravely Products used exclusively for personal, family or household purposes, and two years (24 months) for products used for other purposes (commercial use), excluding rental firms. Gravely products used for rental purposes will be warranted for 90 days. Repair of Gravely Products after the second year (24 months from date of purchase) shall be subject to a \$50.00 deductible for each repair. (After two years, Gravely agrees to repair or replace defective Gravely Products used exclusively for personal, family or household purposes only to the extent that the cost of such warranty covered repair or replacement exceeds \$50.00.)

Batteries are warranted by Gravely for a period of twelve (12) months only. If a battery shall fail within twelve (12) months of purchase, the replacement cost thereof shall be prorated over a twelve-month term based upon the number of months since purchase.
5. To obtain Warranty Service on a Gravely Product (including any battery or other component not manufactured by Gravely), use this procedure:
 - a. Notify the Gravely dealer from whom you purchased the equipment.
 - b. If you have moved and it is not convenient to notify the selling dealer, notify the nearest Gravely dealer. You should supply this dealer with a copy of the bill of sale as proof of the date of purchase.
 - c. Make arrangements to have the equipment delivered to the dealer (refer to paragraph 6 a., below).
 - d. If you have any questions concerning the Gravely Limited Warranty, they should be referred to:

Gravely International, Inc.
One Gravely Lane
Clemmons, NC 27012
Attn: Customer Service Department
 - e. Warranty service on Gravely Products must be performed by an authorized Gravely dealer.
6. This Warranty does not cover the following:
 - a. Transportation to the Gravely dealership. (If the Gravely dealer provides transportation, he will charge for such service.)
 - b. Normal maintenance services and normal replacement of items such as spark plugs, belts, oil, oil filters, air filters, and mower, plow or cultivator blades, gauge wheels, skids and other wear items.
 - c. Any Gravely Product which has been altered or modified in any way.
 - d. Any repair or replacement occasioned by customer neglect or lack of proper maintenance. (The purchaser is responsible for making sure that Gravely Products are operated and serviced as directed in the applicable manual or service instruction. Incorrect use or maintenance will void this Warranty.)
 - e. Any repair occasioned by the use of any attachment not approved by Gravely. (The use of any such unapproved attachment will void this Warranty.)
7. GRAVELY MAKES NO OTHER EXPRESS OR IMPLIED WARRANTIES, OR WARRANTIES AS TO THE MERCHANTABILITY OR FITNESS FOR A PARTICULAR PURPOSE. ALL WARRANTIES ARE LIMITED IN DURATION TO THE TERMS SET OUT IN PARAGRAPH 4, ABOVE. GRAVELY SHALL HAVE NO LIABILITY FOR INCIDENTAL OR CONSEQUENTIAL DAMAGES RESULTING FROM THE BREACH OF ANY WARRANTY, INCLUDING, BUT NOT LIMITED TO, LIABILITY FOR INCONVENIENCE, RENTAL OR PURCHASE OF REPLACEMENT EQUIPMENT, OR FOR LOSS OF PROFITS OR OTHER COMMERCIAL LOSS.
8. Some states do not allow limitations on how long an implied warranty lasts, so the above statement may not apply to you. Some states do not allow the exclusion or limitation of incidental or consequential damages, so the above limitation or exclusion may not apply to you.
9. This Warranty gives you specific legal rights, and you may have other rights which vary from state to state.
10. A Gravely product registration card is supplied with each Gravely Product. Please complete the card and return it to Gravely at the address listed on the card. The equipment registration card will be used by Gravely for:
 - a. Recording date of purchase.
 - b. Notification of owners in compliance with the Consumer Product Safety Act, should any notification be necessary.The return of such card is necessary for your warranty to be effective.
11. This Warranty is not subject to change or modification by anyone, including Gravely dealers and no Gravely dealer is authorized to make any representations or promises on Gravely's behalf.

 **GRAVELY**

One Gravely Lane, Clemmons, NC 27012